

AERA/AERSCO
AERA Technical Services Department
500 Coventry Lane, Suite 180 Crystal Lake IL 60014
Phone 888/324-2372 Fax 888/329-2372

TECHNICAL BULLETIN		
	March 2010 TB 2529	

Diagnosing Accessory Drive Belt / Serpentine Belt Noise On
GM Engines

The AERA Technical committee offers the following information regarding belt diagnosis and the availability of a helpful tool for GM engines. Occasionally customers complain of excessive noise coming from the belt areas of an engine even after belt replacement has occurred.

Several aftermarket companies offer laser alignment tools for accessory drive systems that can be very helpful in eliminating drive belt noise as a result of misaligned pulleys. Typically pricing ranges from \$160 - \$200. GM offers such a tool, Part #EN-49228, labeled a Laser Alignment Tool. The GM Tool program has now made available a competitive, simple to use and time-saving laser tool to assist in achieving precise alignment of the drive belt pulleys. This optional tool removes the guesswork from proper pulley alignment and may serve to reduce comebacks from:

1. - Drive Belt Noise
2. - Accelerated Drive Belt Wear
3. - Drive Belt Slippage

The instructions below are specific only to the truck Gen IV V-8 family of engines. These instructions are only for illustrative purposes to show how the tool may be used. Universal instructions are included in the box with the Laser Alignment Tool - Drive Belt.

- Do not look directly into the beam projected from the laser.
 - Use caution when shining the laser on highly polished or reflective surfaces.
- Laser safety glasses help reduce laser beam glare in many circumstances.
- Always use laser safety glasses when using the laser. Laser safety glasses are not designed to protect eyes from direct laser exposure.

Follow the steps listed below to determine if pulley adjustment is necessary.

This information is provided from the best available sources. However, AERA does not assume responsibility for data accuracy or consequences of its application. Members and others are not authorized to reproduce or distribute this material in any form, or issue it to their branches, divisions, or subsidiaries, etc. at a different location, without written permission.
© Copyright AERA 2006



Reference:	
-------------------	--

TECHNICAL BULLETIN



March 2010

TB 2529

Install the tool onto the power steering pulley. Position the legs of the tool into the outer grooves of the pulley, farthest from the front of the engine.

Figure 1. Laser Alignment Tool Installed (Wrap around Pulley)
(SEE DIAGRAM TAB ABOVE)

4. Install the retaining cord around the pulley and to the legs of the tool.
5. Put on the laser safety glasses provided with the tool.
6. Depress the switch on the rear of the tool to activate the light beam.
7. Rotate the power steering pulley as required to project the light beam onto the crankshaft balancer pulley grooves.
8. Inspect for proper power steering pulley alignment.
9. If the laser beam projects onto the second rib or raised area (1), the pulleys are aligned properly.
10. If the laser beam projects more than one-quarter rib 0.9 mm (0.035 in) misalignment, adjust the position of the power steering pulley as required.
11. Install the serpentine belt to the accessory drive system in the original orientation.
12. Operate the vehicle and verify that the belt noise concern is no longer present.

The AERA Technical Committee

This information is provided from the best available sources. However, AERA does not assume responsibility for data accuracy or consequences of its application. Members and others are not authorized to reproduce or distribute this material in any form, or issue it to their branches, divisions, or subsidiaries, etc. at a different location, without written permission.
© Copyright AERA 2006



Reference:

TECHNICAL BULLETIN



March 2010
TB 2529

Bulletin Diagram: FIGURE 1. LASER ALIGNMENT TOOL INSTALLED - FAILURE ANALYSIS

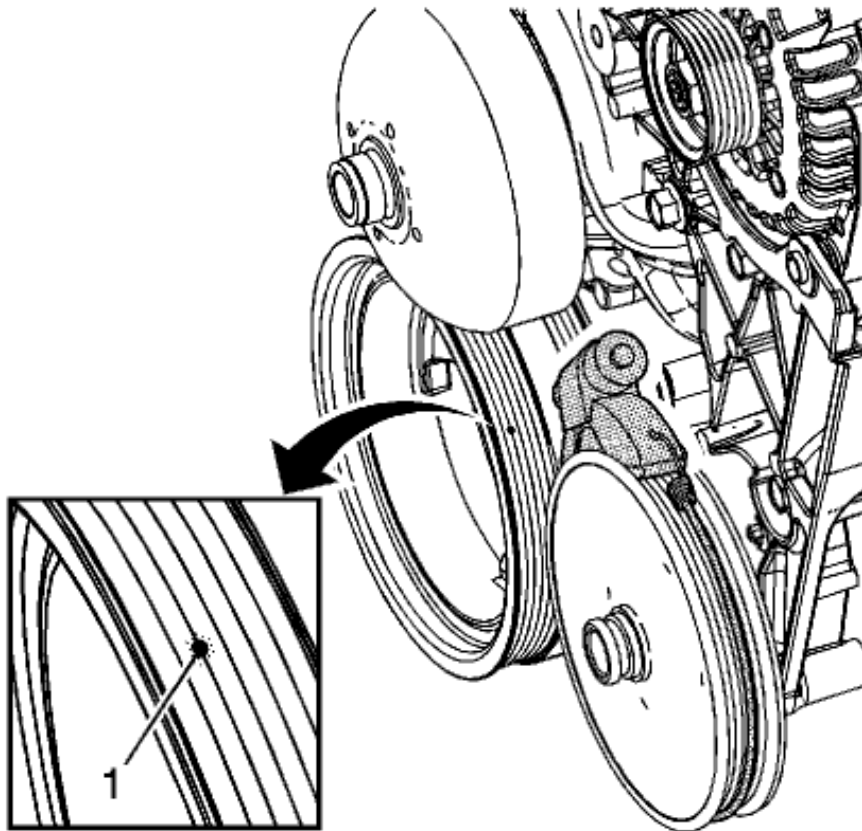

This information is provided from the best available sources. However, AERA does not assume responsibility for data accuracy or consequences of its application. Members and others are not authorized to reproduce or distribute this material in any form, or issue it to their branches, divisions, or subsidiaries, etc. at a different location, without written permission.
© Copyright AERA 2006



Reference: _____